

EO15 PLANTA MÓVIL



VÉHICULO TODOTERRENO 4X4



ÁRIDOS
3,5 m ³
CEMENTO
1,1 m ³
AGUA
550 L
EMULSIÓN
+/- 300 L (opt.)
ADITIVOS
3x42 L (opt.)
PRODUCCIÓN
≤35 m ³ /h

CARACTERÍSTICAS

Motor diesel:	PERKINS serie 1104
Tipología:	Turbo diesel
Refrigeración:	Por agua
Potencia máxima:	62,5 KW (84 HP)
Velocidad nominal:	2200 rpm
Emisiones:	Equivalente EU Stage IIIA / US EPA Tier 3

CINTA DE DESCARGA

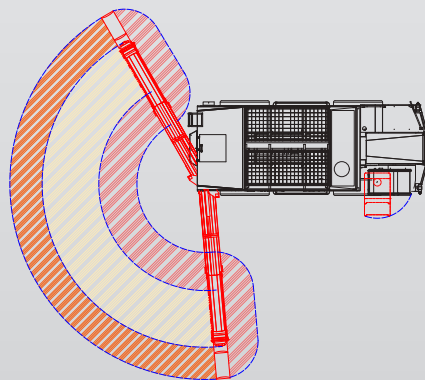

DIRECCIÓN

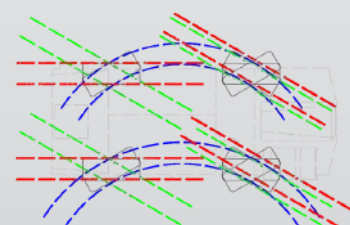

Asiento reversible

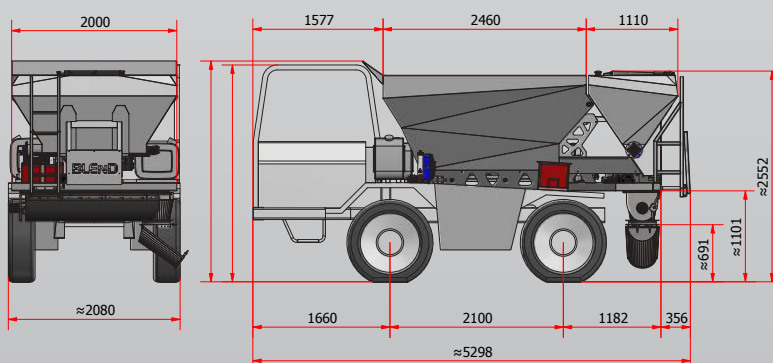

DIMENSIONES

