

# 5

*Motivi per cui la nostra gamma di impianti mobili raggiunge tempi record di installazione ed abbate sensibilmente i costi per la realizzazione di opere di fondazione e murarie.*

Reasons why our range of mobile plants reaches record-time of installation and sensitively cuts the costs of the concrete pillars and foundation works.

1.

**NO FONDAZIONI  
NO FOUNDATIONS**



Assenza di opere di fondazione, sostituite da un telaio in carpenteria per l'appoggio diretto su terreno compattato o platea in calcestruzzo.

*No foundation works, thanks to steel frame for direct support on compacted ground or concrete platform.*

2.

**PRE-ASSEMBLAGGIO  
PRE-ASSEMBLY**



Pre-montaggio, realizzato con strutture completamente zincate a caldo.

*Pre-assembly, realized with fully hot galvanized steel structures.*

3.

**STRUTTURA RAMPA  
IN ACCIAIO  
STEEL RAMP  
STRUCTURE**



Struttura portante della rampa interamente in acciaio e zincata a caldo.

*Structure for the ramp entirely made of steel and hot galvanized.*

4.

**PANNELLI DI STOCCAGGIO  
PREMONTATI  
PRE-MOUNTED  
STORAGE PANELS**



Paratie e sponde laterali di contenimento inerti pre-montate, incernierate ed interamente richiudibili.

*Lateral side panels and bulkhead for aggregate storage are pre-mounted, hinged and entirely folded.*

5.

**PRE-CABLAGGIO  
PRE-WIRING**



Pre-cablaggio, con quadro elettrico e comandi già posizionati in cabina di controllo.

*Pre-wiring, with electric panel and controls already positioned in the control cabin.*

# FAST DRY 2V 60



READY MIX

VISTA LATERALE  
SIDE VIEW

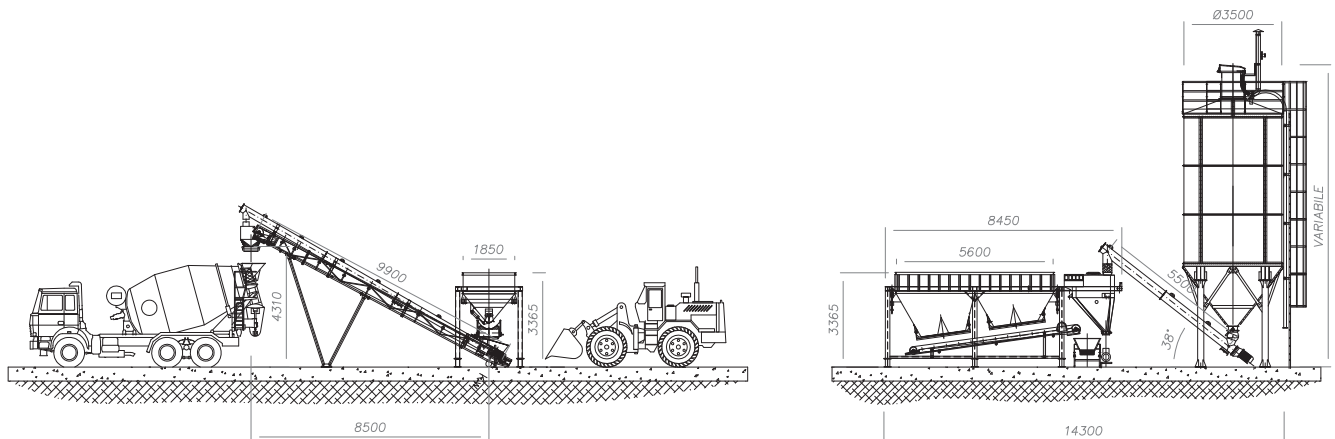

VISTA DALL'ALTO  
TOP VIEW

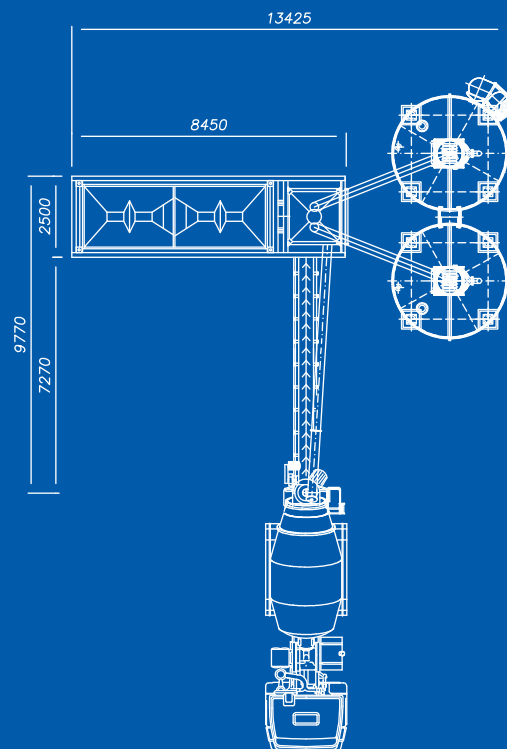

Trasporto: 1 container open top 40' o 1 semirimorchio standard (silos esclusi)  
Shipping: 1 open top 40' container or 1 standard semitrailer (silos excluded)



TECHNICAL DATA - CARATTERISTICHE TECNICHE	SI UNITS	FAST DRY 2V 60	US UNITS	FAST DRY 2V 60
<b>Theoretical hourly output</b> - Produzione oraria teorica	m <sup>3</sup> /h	60	yd <sup>3</sup> /h	78.5
<b>Aggregate storage bins</b> - Vasche inerti	n.	2	n°	2
<b>Discharge gates/Pneumatic cylinders</b> - Bochette/Cilindri pneumatici	n.	2	n°	2
<b>Aggregate weighing system</b> - Sistema di pesatura inerti	kg	20000	lb	44080
<b>Cement weighing system</b> - Sistema di pesatura cemento	kg	4000	lb	8816
<b>Water meter</b> - Contaltri	in	2	in	2
<b>Loading belt with sheet 800 mm</b> - Nastro caricatore telo 800 mm	°	28	°	28
<b>Extractor belt with sheet 800 mm</b> - Nastro estraattore telo 800 mm	m <sup>3</sup> /h	180	yd <sup>3</sup> /h	235.4
<b>Air compressor</b> - Compressore aria	l	270	l	270
<b>Operating voltage</b> - Tensione di esercizio	V	400	V	400
<b>Operating frequency</b> - Frequenza di esercizio	Hz	50/60	Hz	50/60
<b>Absorbed electrical power</b> - Potenza elettrica assorbita**	kW	30	hp	40.2
<b>Installed electrical power</b> - Potenza elettrica installata**	kW	37	hp	49.6

\*\*basic version and for n.2 silos - versione standard e per n.2 silos